

PART NUMBER	DESCRIPTION	MATERIAL	WEIGHT	STOCK SIZE
1000853-6	MOUNT, GAS SPRING, 3/8-16 X .875	6061-T6	0.10	ROUND 1" X 15/16" LG

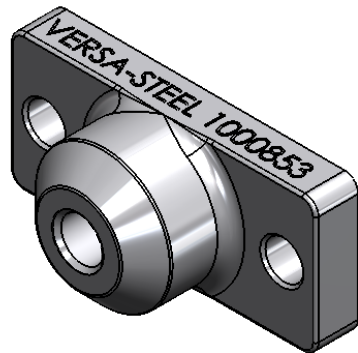
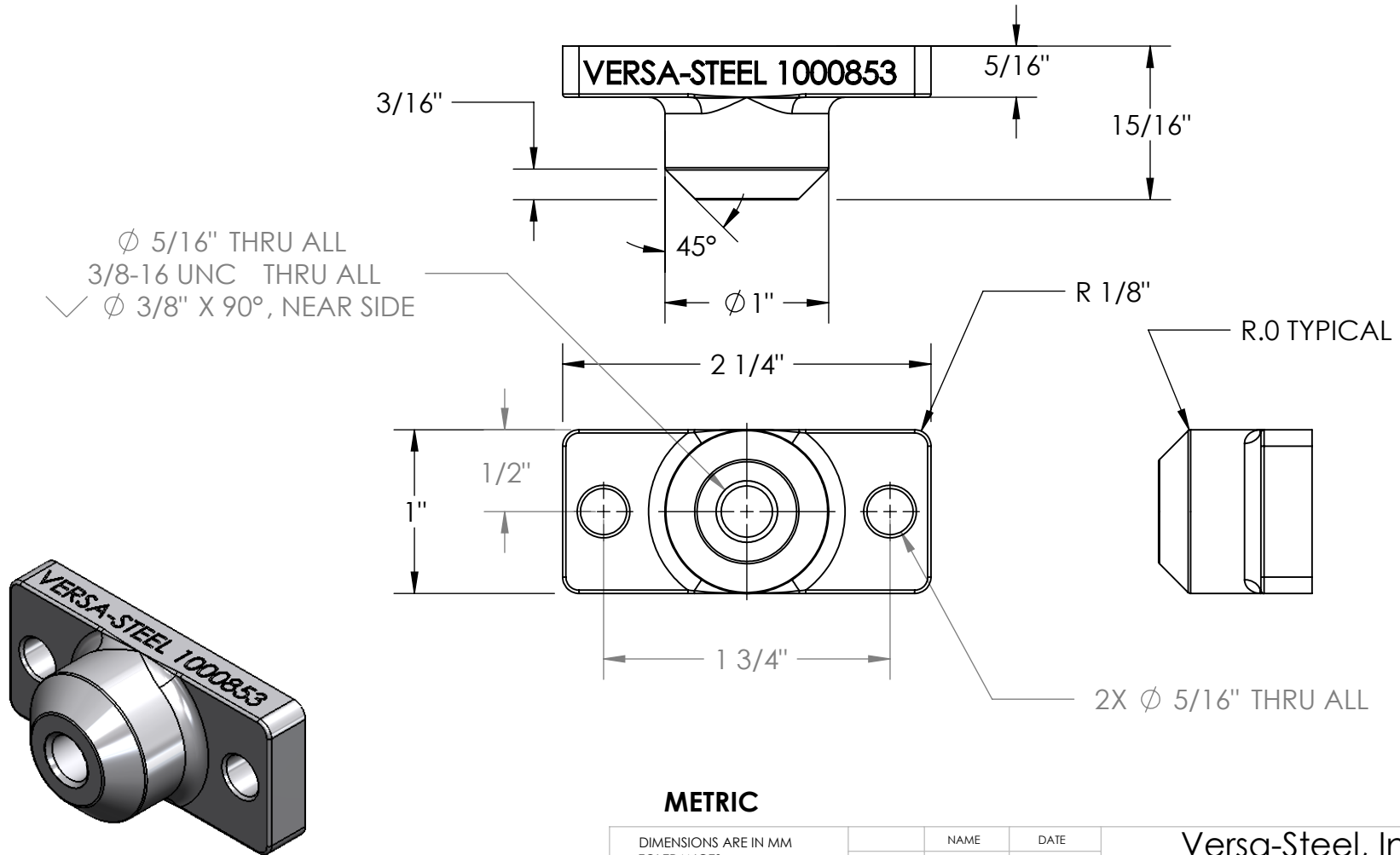

METRIC

DIMENSIONS ARE IN MM
 TOLERANCES:
 0mm = \pm 1mm
 0.0mm = \pm 0.5mm
 0.00mm = \pm 0.025mm

MATERIAL
6061-T6
 FINISH
BEAD BLAST
 DO NOT SCALE DRAWING

	NAME	DATE
DRAWN	E.BAILIFF	2010-9-22
CHECKED		
ENG APPR.		
MFG APPR.		
Q.A.		
COMMENTS:		

Versa-Steel, Inc
 Portland, Oregon USA
 Ph 503-287-9822

Description: MOUNT, GAS SPRING,
 3/8-16 X .875
 Part Number: 1000853-6-M

SIZE A	DWG. NO. 1 of 1	REV. A
SCALE: 1:2	WEIGHT: 0.10 Kgs	SHEET 1 OF 1

PROPRIETARY AND CONFIDENTIAL

THE INFORMATION CONTAINED IN THIS
 DRAWING IS THE SOLE PROPERTY OF
 VERSA-STEEL, INC. ANY
 REPRODUCTION IN PART OR AS A WHOLE
 WITHOUT THE WRITTEN PERMISSION OF
 VERSA-STEEL, INC. IS PROHIBITED.